



800-428-8560
midwesthomes4pets.com
3142 S. Cowan Rd.
Muncie, Indiana 47302



Assembly Instructions for Model Number K910106



Assembly Videos and Instruction Manuals can be viewed at midwesthomes4pets.com.

For instructions in Spanish and French, please visit www.midwesthomes4pets.com.

IMPORTANT INFORMATION

Warning: Remove collars, tags, and leads from pet before placing it in the kennel to prevent possible entanglement. DO NOT leave young animals unsupervised for extended periods of time. MidWest's main concern is your pet's well-being. If your pet has never been kept in any enclosure, specific training may be necessary for your pet's safety. A pet, not specifically trained to be restricted, may attempt to escape from this enclosure, which could cause serious injury to your pet or damage to this product. MidWest will not accept liability or warrant any loss to improper use of this product by a pet that has not been properly trained.

Warranty Information

Unwrap and remove all parts from the box. Keep the box and packing material until the product is assembled. In case of return or exchange, failure to return product in similar condition as received could result in limited reimbursement. Please save sales receipt as proof of purchase for warranty purposes. Check to ensure you have all the parts below. If you discover any parts are missing, immediately call our toll-free service helpline at 1-800-428-8560 (Monday - Friday 9 a.m. to 4 p.m. EST) or at info@midwesthomes4pets.com.

Helpful Hints

Please take time to read and follow these instructions. To make set-up easier, locate a level area to assemble your kennel. Remove all components from the carton and arrange them as shown on Page 2. You will need a pair of pliers and an adjustable wrench to assemble your kennel. We recommend two people assemble the kennel together.

The chain-link fence comes in one continuous 40' piece. It is prone to tangle while attaching, but with two people and a little patience, the fence can be applied with minimal complication. The best practice is to unroll the fence and stretch it out completely to undo any tangling. Then, using two people, lift, pull, and stretch the chain-link fence around the perimeter one small section at a time.

Sunscreen Safety

Your K9 Kennel comes with a Sunscreen. We suggest removing and storing the Sunscreen when not needed to shade your pet. Do not allow snow or debris to collect on top of the Sunscreen. Occasionally, even rain will collect. Remove it as soon as possible. Injury to your pet and damage to your Kennel may occur if the load is not removed. Properly cared for, your Sunscreen will provide years of service and protection for your pet.

PARTS IDENTIFICATION

- A. Bent Bottom Rail with short corner peg - two rails have no swaged ends; two rails have one swaged end (4)
- B. Long Filler Rail - swaged on one end (3)
- C. Medium Filler Rail - Long - swaged on both ends (3)
- D. Medium Filler Rail - Short - swaged on one end (3)
- E. Short Filler Rail - swaged on one end (3)
- F. Gate Frame - two pieces
- G. Vertical Corner Posts - swaged on one end (8)
- H. Bent Middle Rail with one long and one short corner peg - two rails have no swaged ends; two rails have one swaged end (4)
- I. Bent Top Rail with one long corner peg - two rails have no swaged ends; two rails have one swaged end (4)
- J. Vertical Tension Rod - 5/16th Diameter (2)
- K. Gate Door (1)
- L. Chain-Link Fence (1)
- M. Sunscreen Top (1)
- N. Short Plastic Ties (100)
- O. Long Plastic Ties (28)
- P. Scored Eyebolt with Nut (8)
- Q. Black Plastic Cap (8)
- R. Small Bolt, Nut, and Acorn Nut (2 each)

Swaged End - Reduced, Smaller Diameter

The Vertical Corner Posts (G), Long Filler Rails (B), Short Filler Rails (E), two of the Bent Top Rails (I), two of the Bent Middle Rails (H), two of the Bent Bottom Rails (A), and the three Medium Filler Rails - Short (D) have one swaged end. The three Medium Filler Rails - Long (C) are swaged on both ends.

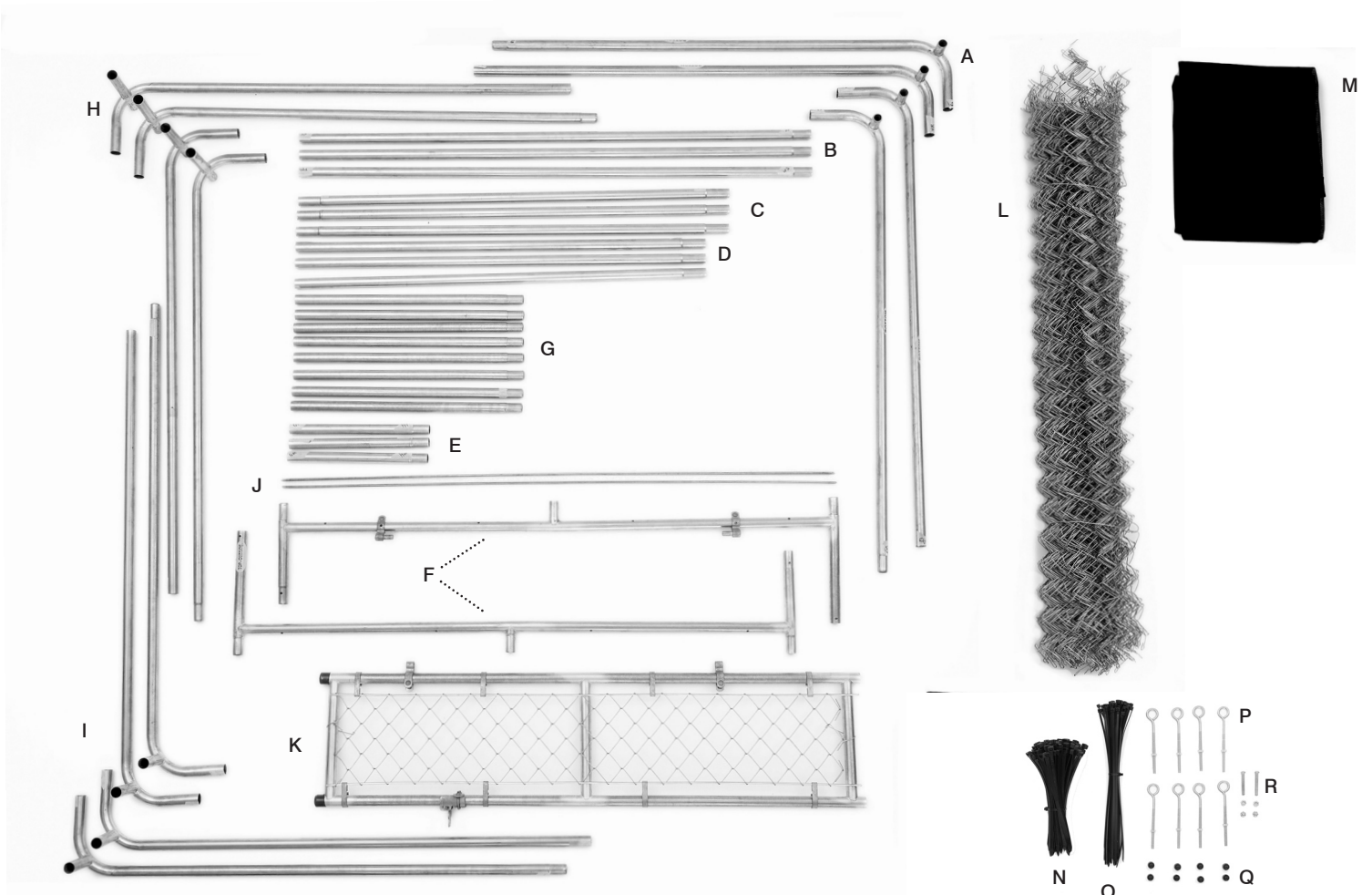

ASSEMBLY INSTRUCTIONS

1. Place the four Bent Bottom Rails (A) on the corners as shown. The small pegs on the Bent Bottom Rails must point up. In the front, place a Short Filler Rail (E), Long Filler Rail (B), and the two sections of the Gate Frame (F) on the ground as shown. Place a Medium Filler Rail Long (C) and a Medium Filler Rail Short (D) in the back. **Note the placement of the swaged ends on each rail.**

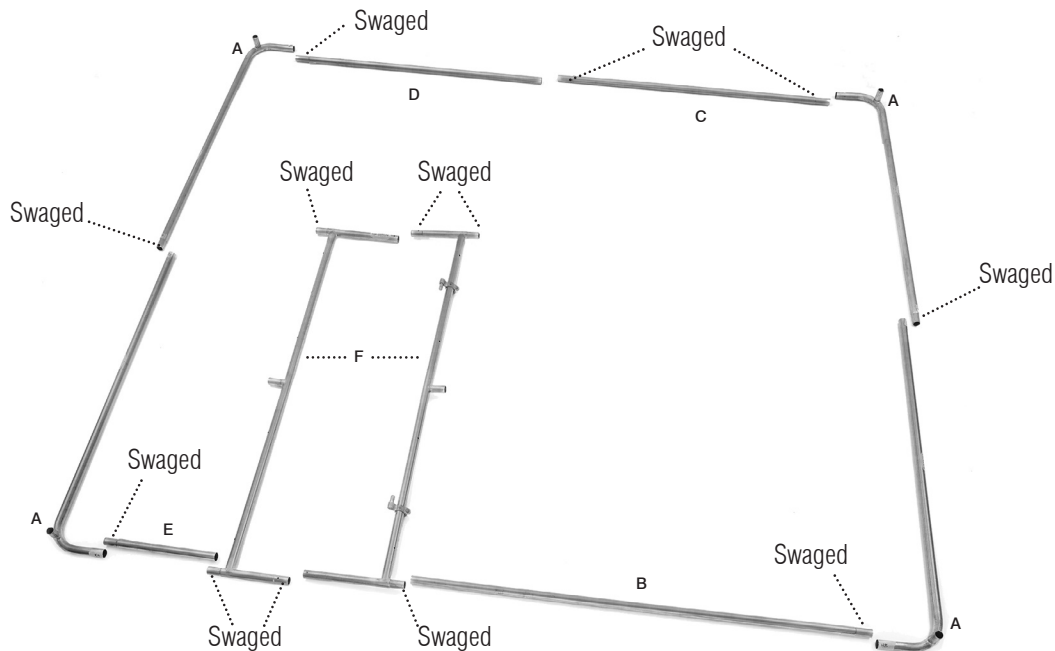

2. Connect the two sides of the Gate Frame. Using a Small Bolt, Nut, and Acorn Nut (R), secure the two sections together at the top and the bottom of the frame.

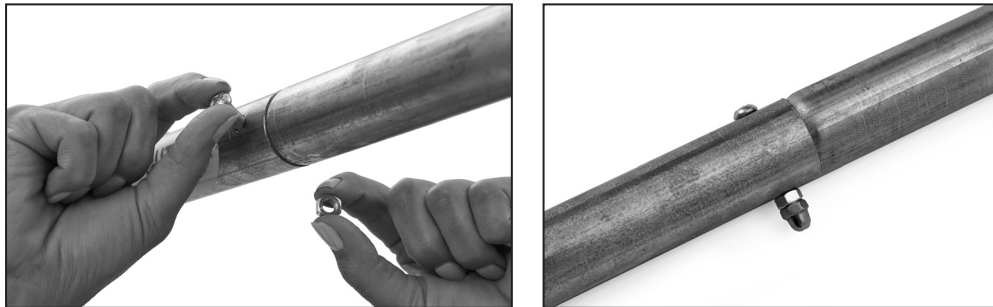

3. Push the swaged ends of each rail into the non-swaged ends of each adjacent rail, making sure all pieces are pushed in completely and put together firmly.

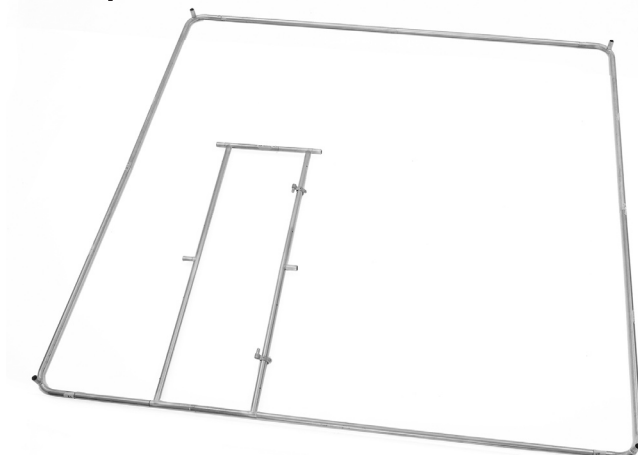

4. On each corner, push the non-swaged end of a Vertical Corner Post (G) onto the short corner peg of each Bent Bottom Rail.

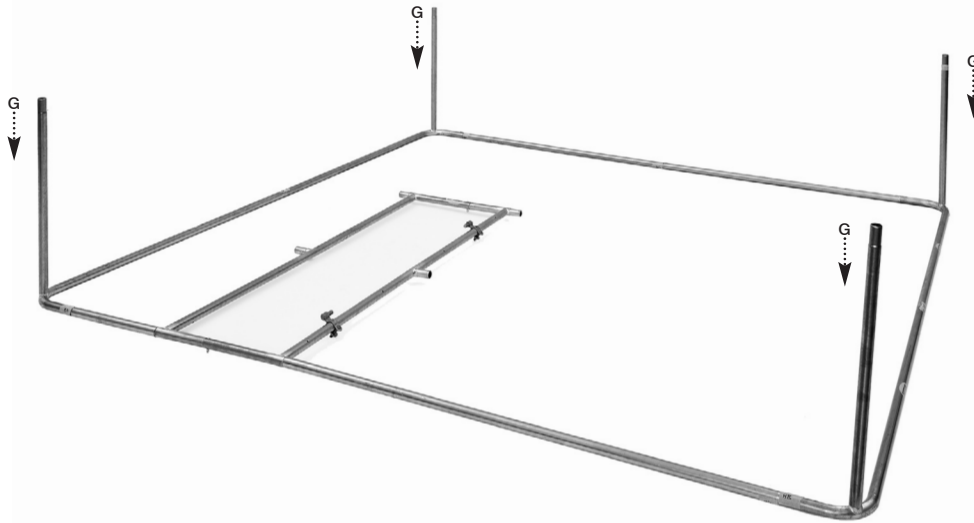

5. To assemble the middle rail, start at the corner closest to the Gate Frame. Swing the Gate Frame into the upright position. Use a Short Filler Rail (E) to connect the Gate Frame to a Bent Middle Rail (H) with NO swaged ends. Secure the long peg of the Bent Middle Rail on the Vertical Corner Post.

Attach Bent Middle Rail (H), with one swaged end and one non-swaged end, to the Bent Middle Rail already in place, and secure it on the Vertical Corner Post in the back.

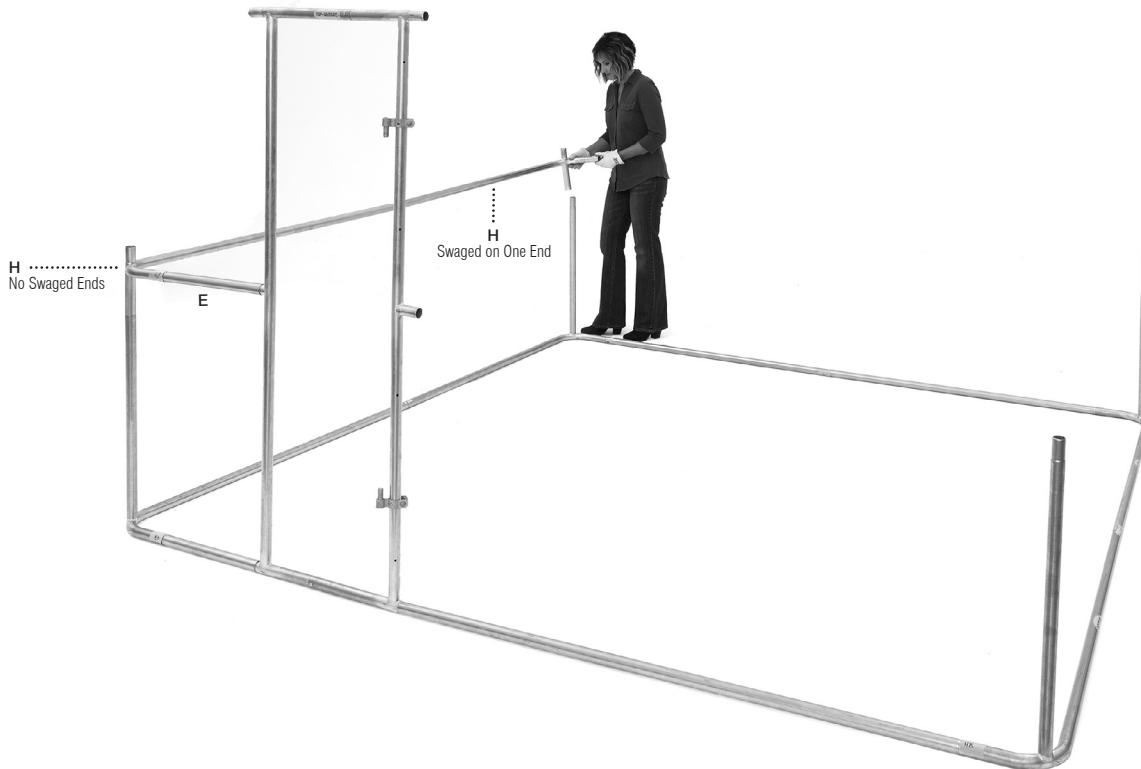

6. Moving to the front, attach a Long Filler Rail (B) to the right side of the Gate Frame. Connect the Long Filler Rail to a Bent Middle Rail with NO swaged ends. The bent rail will fit onto the Vertical Corner Post.



7. Place the final Bent Middle Rail (H) with one swaged end and one non-swaged end on the last Vertical Corner Post. Connect the two Bent Middle Rails on the side.

Use one Medium Filler Rail - Long (C) with two swaged ends and one Medium Filler Rail Short (D) with one swaged end to complete the back.

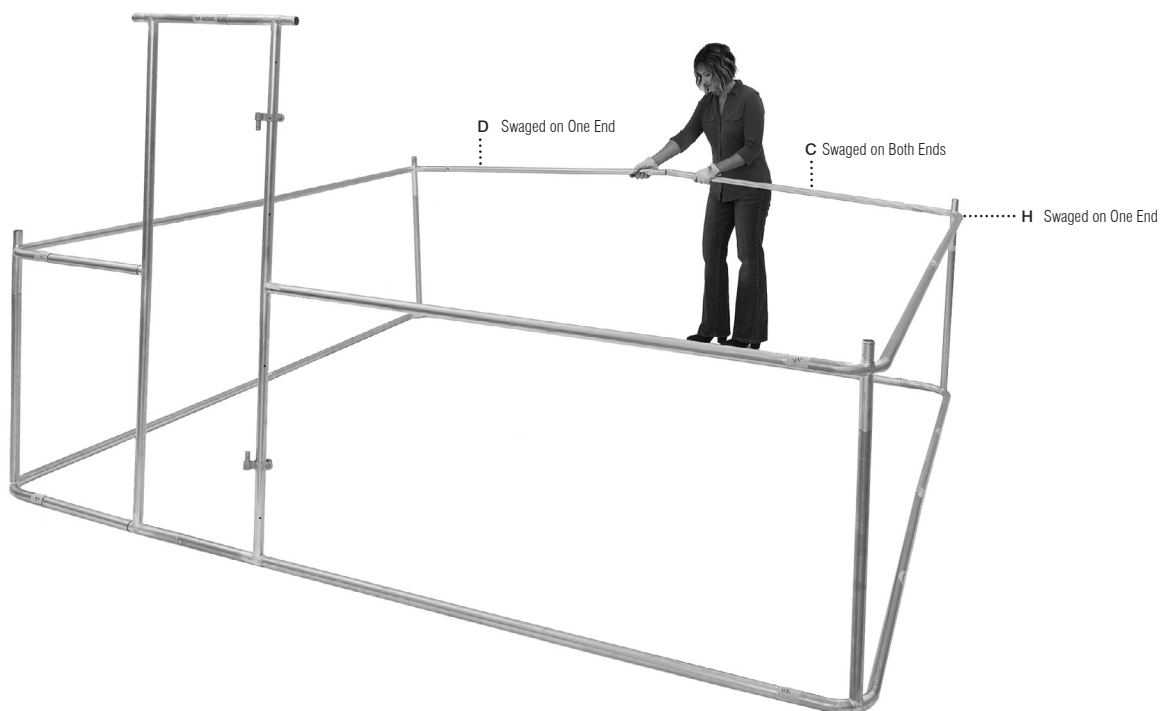

8. On each corner, push the non-swaged end of a Vertical Corner Post (G) onto the short corner peg of each Bent Middle Rail.

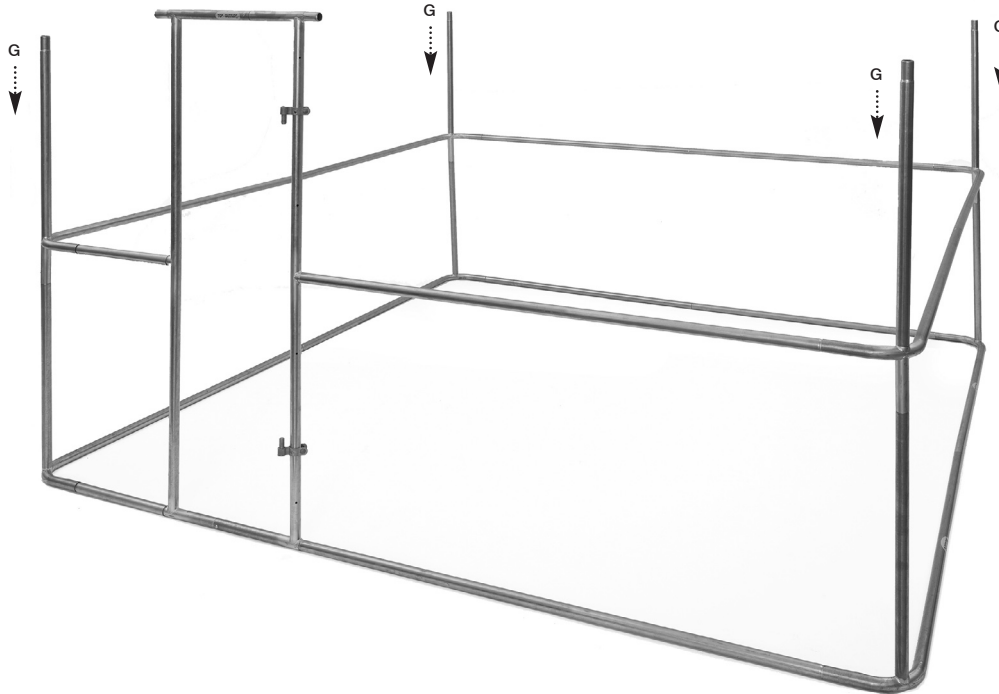

9. To assemble the top rail, start at the corner closest to the Gate Frame. Use a Short Filler Rail (E) to connect the Gate Frame and a Bent Top Rail (I) with NO swaged ends. Place the long peg on the Bent Top Rail over the Vertical Corner Post.

Locate a second Bent Top Rail (I) with one swaged end and one non-swaged end. Connect this to the first Bent Top Rail and slide over the Vertical Corner Post in the back.

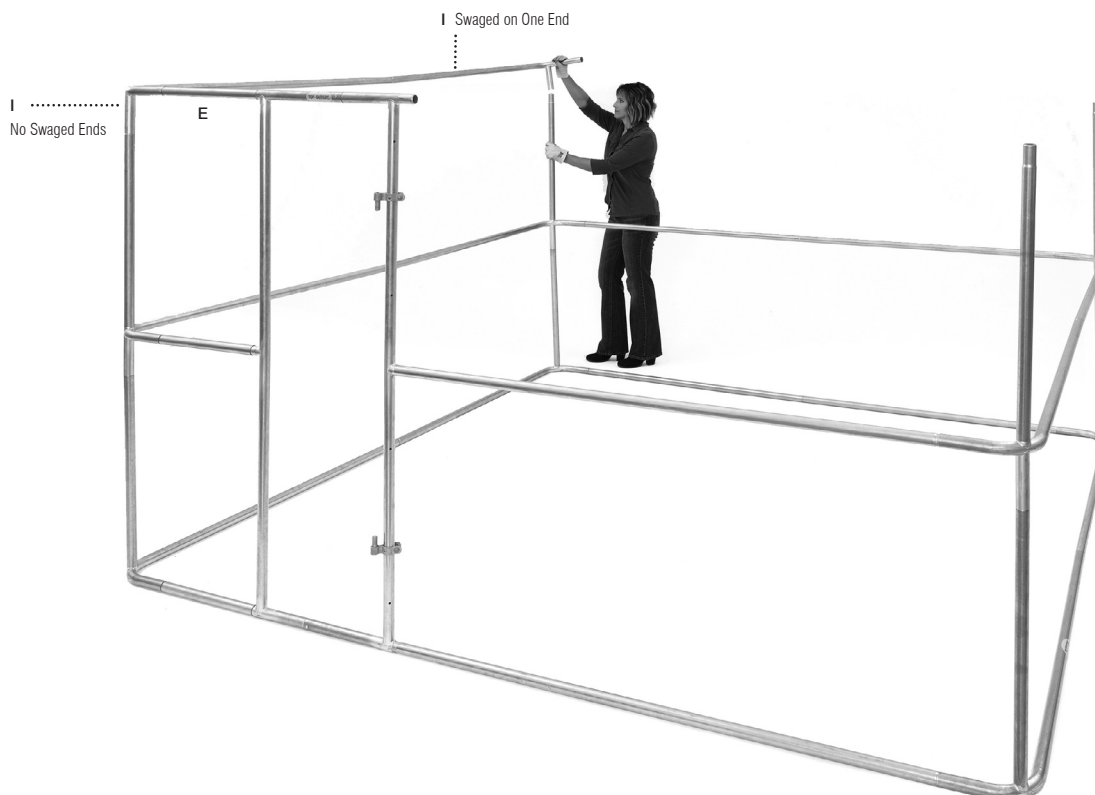

10. Moving to the front, attach a Long Filler Rail (B) to the right side of the Gate Frame. Connect the Long Filler Rail to a Bent Top Rail (I) with NO swaged ends. The bent rail will fit onto the Vertical Corner Post.
11. Continuing to the back, place the final Bent Top Rail on the Vertical Corner Post. The swaged end of this rail will connect with the non-swaged end of the Bent Top Rail in the front.

Use one Medium Filler Rail - Long with two swaged ends and one Medium Filler Rail - Short with one swaged end to complete the back.



12. It's time to install the Gate Door (K) in the Gate Frame (F). The hinge pins are fixed on the Gate Frame and do not adjust. The hinge knuckles, on the Door, will be loose until you tighten them.

Begin by aligning the bottom pin and the bottom knuckle. Adjust the bottom knuckle as needed, making sure that when the door swings, the bottom of the door will clear the bottom rail on the ground and the top of the door will clear the top rail. Slide the knuckle over the pin and loosely tighten the knuckle, as you might need to adjust slightly after step 13.



13. Align the top knuckle with the top pin on the door. Adjust the top knuckle as needed, making sure that when the door swings, the bottom of the door will clear the bottom rail on the ground and that the top of the door will clear the top rail. Slide the knuckle over the pin and loosely tighten the knuckle. Check once more to ensure the knuckle placement will allow the door to swing within the opening. Then, use a wrench or socket wrench to tighten the bolts on the door's knuckles.



NOTE: At this point, you will begin attaching the chain-link fence. The chain-link fence comes in one continuous 40' piece. It is prone to tangle while attaching, but with two people and a little patience, the fence can be applied with minimal complication. The best practice is to unroll the fence and stretch it out completely to undo any tangling. Then, using two people, lift, pull, and stretch the chain-link fence around the perimeter one small section at a time. About every four feet, loosely attach a Large Black Plastic Tie to keep the chain-link in place until it is ready to be fully secured.

14. With the Gate door open, insert the Eyebolts (P), with the eye to the outside of the kennel, through the eight holes in the Gate's frame (four on each side). Start the Nuts onto the end of the bolts about 1/2" as shown. **WAIT to tighten all the way.**



15. Next, stand one end of the Chain-Link Fence (L) up against the left side of the Gate frame. Starting at the top, thread the Vertical Tension Rod (J) down through the Chain-Link Fence, front/back, front/back, through each diamond, while making sure to pass through the eye of each Eyebolt on the way down. Thread the rod all the way through the last diamond at the bottom.



16. Unroll the Chain-link Fence around the frame of the kennel, being sure to keep tension on the wire by pulling the roll as you unwind it. Occasionally, it may be necessary to untangle the knuckles at the top and bottom of the roll. Keeping the tension on the roll tight will help prevent this.

NOTE: As noted on page 8, with two people the fence can be fully unrolled, stretched out in its entirety, and lifted, pulled, and stretched around the perimeter one small section at a time. This will minimize bunching and tangling of the fence during application.

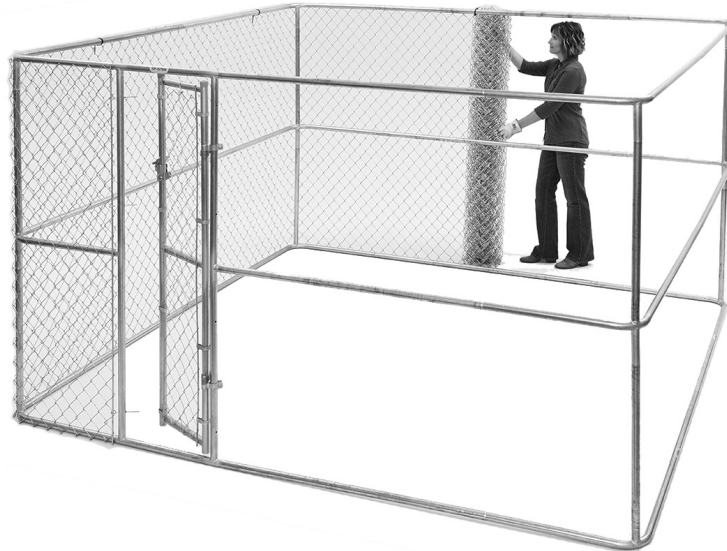

17. About every four feet, loosely attach a Short Plastic Tie (N) at the top to keep the chain-link in place until it is ready to be fully secured.



18. After you have unrolled the Chain-Link Fence completely around the frame, you may find that you have several extra inches of wire that extend past the last set of Eyebolts. This excess must be removed. Pull the Chain-Link Fence tightly past the Eyebolts to determine where to remove the extra fencing so that the second Tension Rod can be installed as in Step 15.

To determine how much Chain-Link Fence to remove, slide the second Vertical Tension Rod down through the Chain-Link Fence so it will pass through the eye of the first Eyebolt. It is the extra Chain-Link Fence on the Gate side of the Tension Rod that must be removed. Locate and note the top knuckle of the fence on the Gate side of the Tension Rod. Remove the Tension Rod.

19. Unbend the loop of the knuckle you identified so that it is straight. Locate the corresponding knuckle at the bottom of the Chain-Link Fence. Unbend that loop. This single “picket” can now be removed. Lift and rotate the picket until it is completely removed from the fencing.



20. Once all excess fencing has been removed, insert the second Tension Rod down through the Chain-link Fence and the Eyebolts on the other side of the gate, as you did in Step 15.

21. Facing the Kennel, go to the top, left Eyebolt. Push the “eye” firmly against the Gate Frame. Tighten the Nut past the scored area of the bolt’s threads. Move down to the next Eyebolt and repeat. Pulling the Tension Rod against the Gate Frame as you go, proceed around the Gate Frame until all eight Eyebolts have been tightened. This step will tighten the fit of the Chain-Link Fence around the frame.



22. Use pliers to grip the exposed threads and snap off the excess at the scored area of the bolt. Finish each nut with a Plastic Cap (Q).



23. Starting at the Gate Frame, install Short Plastic Ties (N) every two feet, securing the Chain-Link Fence to the Top Rail of the Kennel. Do the same with the Middle and Bottom Rails, installing the ties with closer spacing, approximately every 12 inches.

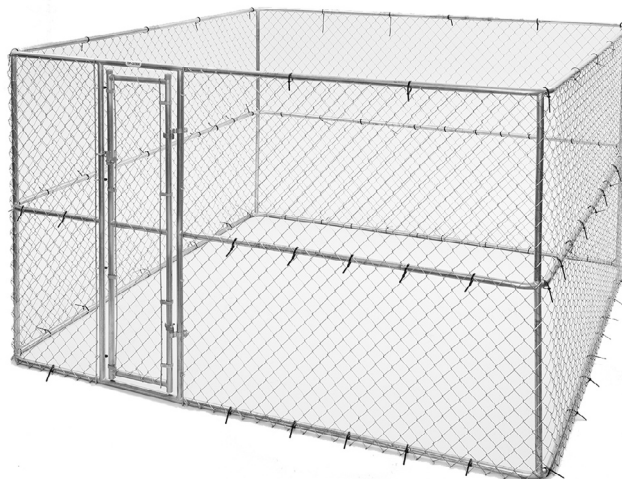

Sunscreen Installation

24. Unfold the Sunscreen (M) and, using the Long Plastic Ties (O), loosely attach it to the Bent Top Rail of the Kennel at each corner. **DO NOT PULL THEM TIGHT!**

After the corners have been attached, loosely affix a Long Plastic Tie at each grommet on the Sunscreen around the perimeter. Starting at one corner, pull the tie a bit tighter. Work your way around to each corner, pulling the ties tighter and tighter until they are all snug. Now work your way around the kennel, pulling the remaining ties up as you go.

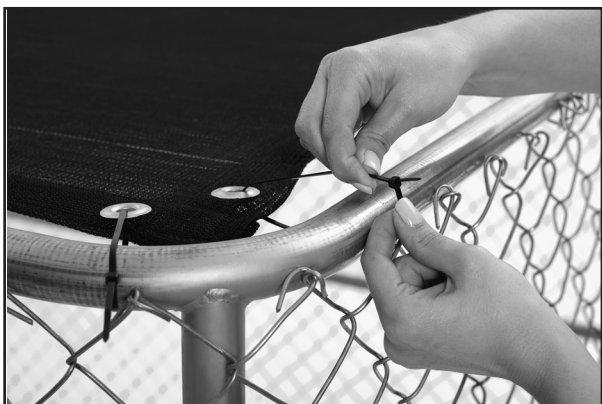

We suggest removing and storing the Sunscreen when not needed to shade your pet. Do not allow snow or debris to collect on top of the Sunscreen. Occasionally, even rain will collect. Remove it as soon as possible. Injury to your pet and damage to your Kennel may occur if the load is not removed. Properly cared for, your Sunscreen will provide years of service and protection for your pet.

TOLL-FREE SERVICE HELPLINE: If you have any problems or questions with the assembly of your new K9 Kennel call our Service Helpline at: 1-800-428-8560 between 9:00 a.m. and 4:00 p.m. (EST) Monday through Friday.

On our web page, www.midwesthomes4pets.com, you will find fully illustrated, printable instructions! You will also find additional product information and tips on training and using MidWest crates.

LIMITED MANUFACTURER'S WARRANTY

1. For one (1) year from the date of original purchase, MIDWEST Homes For Pets ("MIDWEST") warrants to the purchaser of this kennel that, should it prove defective by reason of improper workmanship and/or material, MIDWEST will repair or replace, at its option, any defective part of the kennel, without charge for the part or for shipping. Replacement parts are warranted for the remainder of the original period.
2. THIS WARRANTY DOES NOT COVER defects in the kennel caused by any animal, any physical abuse to or misuse of the kennel, any damage caused by the original purchaser or any third party, or any defects arising or discovered more than one (1) year from the original retail purchase date.
3. STEPS TO OBTAIN WARRANTY SERVICE:
 - A. The purchaser must call MIDWEST's HELPLINE, 800-428-8560, to report the alleged defect to a customer service representative or obtain missing parts.
 - B. The customer service representative will determine if the defect is covered by this warranty, and if it is, will authorize and instruct the purchaser in how to obtain corrective action.
 - C. MIDWEST may require the purchaser to present the sales receipt or other proof of purchase prior to authorizing any return or replacement. No returns or replacements will be permitted without proper authorization. If a return or replacement is authorized, you may be requested to return the item to MIDWEST or to make the item available for pick-up by MIDWEST.
4. ANY EXPRESS WARRANTY NOT PROVIDED IN THIS WARRANTY DOCUMENT, AND ANY REMEDY FOR BREACH OF CONTRACT THAT, BUT FOR THIS PROVISION, MIGHT ARISE BY IMPLICATION OR OPERATION OF LAW, IS HEREBY EXCLUDED AND DISCLAIMED. THE IMPLIED WARRANTIES OF MERCHANTABILITY AND OF FITNESS FOR ANY PARTICULAR PURPOSE ARE EXPRESSLY LIMITED TO A TERM OF ONE (1) YEAR. SOME STATES DO NOT ALLOW LIMITATIONS ON HOW LONG AN IMPLIED WARRANTY LASTS, SO THE ABOVE LIMITATIONS MAY NOT APPLY TO YOU.
5. UNDER NO CIRCUMSTANCES SHALL MIDWEST BE LIABLE TO PURCHASER OR ANY OTHER PERSON FOR ANY SPECIAL, INCIDENTAL, OR CONSEQUENTIAL DAMAGES, WHETHER ARISING OUT OF BREACH OF WARRANTY, BREACH OF CONTRACT, OR OTHERWISE. SOME STATES DO NOT ALLOW THE EXCLUSION OR LIMITATIONS OF INCIDENTAL OR CONSEQUENTIAL DAMAGES, SO THE ABOVE LIMITATIONS OR EXCLUSION MAY NOT APPLY TO YOU.
6. This warranty gives you specific legal rights, and you may also have other rights which vary from state to state.

For a Complete Listing of Products

**Crates • Pet Beds • Exercise Pens
Feed Bowls • Pet Gates . . .**

*- Come Visit Our Website
www.midwesthomes4pets.com*

